

SPECIFICATIONS

Laser Particle Sensor

Model: PMJG-200

Version: V1.2



1. Overview

PMJG-200 is a laser-based particle sensor which uses light scattering method to count particles and calculate PM1.0, PM2.5 and PM10 concentration in a given environment. The sensor features an imported processing chip and photosensitive element. Signals are collected and processed by the microprocessor chip and then output in digital format. The sensor is ideal to detect the concentration of different particles precisely in real time.

2. Applications

Air purifiers, air quality detectors, fresh air systems, air conditioners and automobiles with air purifying function, consumer electronics.

3. Value to Customers

Consistent, stable, reliable.

Small zero drift, good repeatability.

Compact size, easy to mount.

Low power consumption, long service life.
 High sensitivity, fast response.
 Proven EMC and EMI performance, strong anti-interference.

4. Working Principle

The sensor is based on the particle concentration analysis technology of Mie scattering theory. A laser light source illuminates a particle as it is pulled through the detection chamber. The particles are scattering when passing through the laser beam. The information processing circuit converts the light intensity signal of the scattered light via the photoelectric sensor into a voltage pulse signal, which is preamplified, converted by AD into digital signal. After noise processing and optimal algorithm analysis, particle count with the equivalent particle size per unit volume can be obtained, and then the particle concentration is calculated. Refer to the following figure for how the principle works:

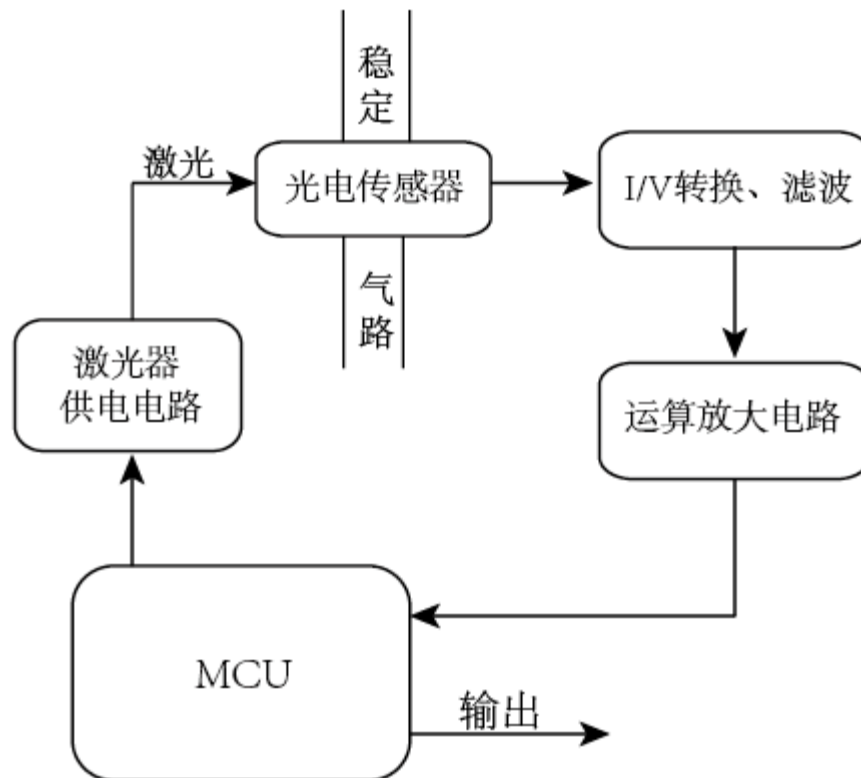

激光器供电电路 Laser supply circuit
 激光 Laser
 稳定气路 Stable air duct
 光电传感器 Photoelectric sensor
 I/V 转换、滤波 I/V conversion, smoothing
 运算放大电路 Operational amplifier circuit
 输出 Output

5. Technical Data

Output data	PM1.0, PM2.5, PM10 concentration and
-------------	--------------------------------------

	particle count
Concentration range (PM2.5)	0~999 $\mu\text{g}/\text{m}^3$
Effective range (PM2.5)	0-500 $\mu\text{g}/\text{m}^3$
Accuracy	$\pm 10\mu\text{g}/\text{m}^3$ (0-100 $\mu\text{g}/\text{m}^3$) $\pm 10\%$ (100-500 $\mu\text{g}/\text{m}^3$)
Minimum distinguishable particle diameter	0.3 μm
Power supply	5V $\pm 0.1\text{V}$ (Ripple < 100mV)
Max working current	100mA
Working temperature	-10 $^{\circ}\text{C}$ ~ 60 $^{\circ}\text{C}$
Working humidity	0~95%RH(non-condensing)
Storage temperature	-30 $^{\circ}\text{C}$ ~ 70 $^{\circ}\text{C}$
Response time	<1.5s
Resolution	1 $\mu\text{g}/\text{m}^3$
Maximum dimensions	448.x24x15.4mm

6. Connector Pinout

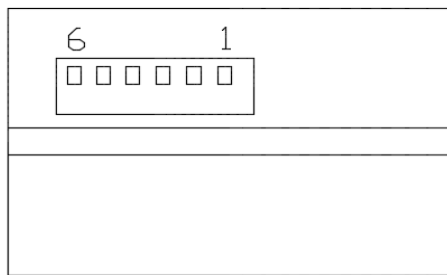

Connector Definition

Pin	Name	Description
1	VCC	5V
2	GND	N/A
3	RX	UART RX output (0-3.3V)
4	TX	UART TX output (0-3.3V)
5	CTRL	Control pin, active at high level, level voltage: 3.3V; inactive at low level
6	NC	N/A

Note: Sensor port is a horizontal connector SH1.0-6PIN.

7. Communications Protocol

Serial communication protocol: 115200 N1 (Rate:115200, data bit: 8, parity: none, stop bit: 1).

Serial communication reporting period: 1.5s

Name	Description	Note
Start bit 1	0x4A	
Start bit 2	0x43	
PM2.5	0xXX, 0xXX, 0xXX, 0xXX,	32 bit floating point - IEEE-754 format
PM10	0xXX, 0xXX, 0xXX, 0xXX,	32 bit floating point - IEEE-754 format
PM1.0	0xXX, 0xXX, 0xXX, 0xXX,	32 bit floating point - IEEE-754 format
0.3 particle count	0xXX, 0xXX, 0xXX, 0xXX,	32 bit floating point - IEEE-754 format
Checksum	The checksum of 16 bytes from PM2.5 to 0.3 particles	8 low bits are effective
End bit	0x0D	

For example:

Name	Description
Start bit 1	0x4A
Start bit 2	0x43
PM2.5	0x00, 0x00, 0xA4, 0x41,
PM10	0x33, 0x33, 0x23, 0x41,
PM1.0	0xC3, 0xF5, 0x60, 0x42,
0.3 particle count	0xD7, 0xA3, 0xBA, 0x41,
Checksum	0x7E
End bit	0x0D

PM2.5: 0x41A40000=20.5ug/m³

PM10: 0x41233333=10.2ug/m³

PM1.0:0x4260F5C3 = 56.2 ug/m³

0.3 particle count: 0x41BAA3D7 = 23 pcs/L

Users can define a struct variable.

```
union {float a; unsigned char A[4]} PM25
```

If users' microprocessor is in little endian format, data will be processed as follows:

```
PM25.A[0]=0x00;
```

```
PM25.A[1]=0x00;
```

```
PM25.A[2]=0xA4;
```

```
PM25.A[3]=0x41;
```

```
PM25.a=20.5
```

If the user's microprocessor is in big endian format, data will be processed as follows:

```
PM25.A[0]=0x41;
```

```
PM25.A[1]=0xA4;
```

PM25.A[2]=0x00;

PM25.A[3]=0x00;

PM25.a=20.5

8. Dimensions

进风口: Air inlet

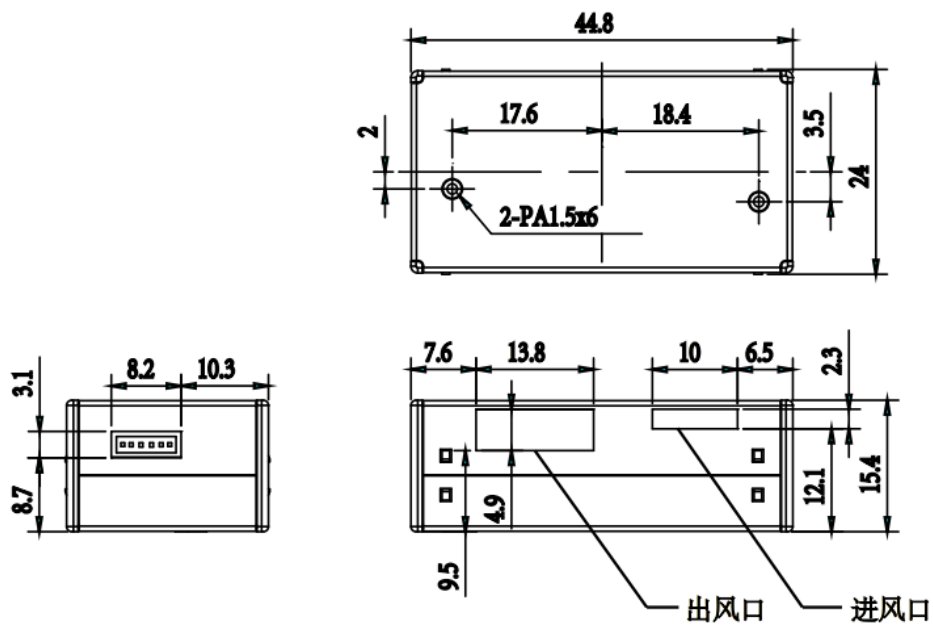

9. Typical Output Features

9.1 Compliance at room temperature

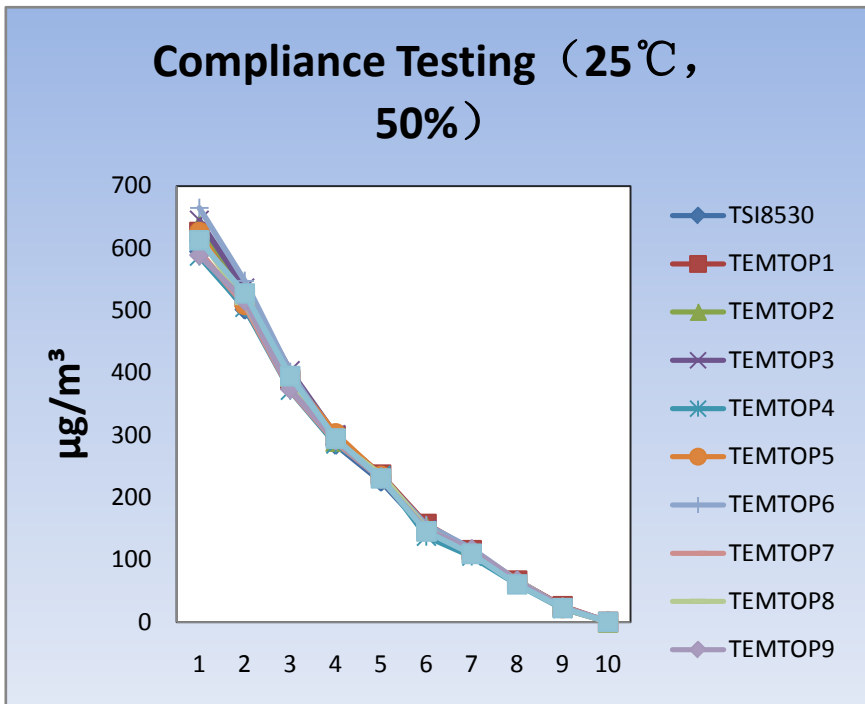

9.2 Compliance at low temperature

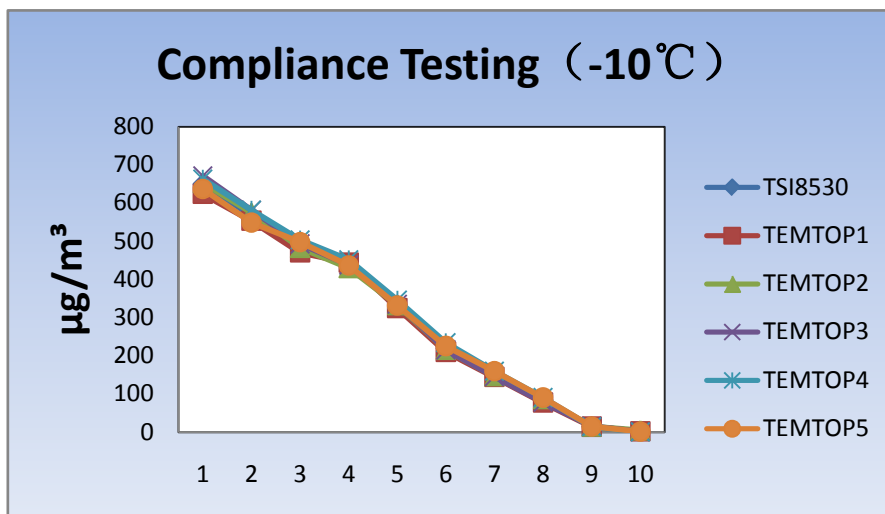

9.3 Compliance at high temperature

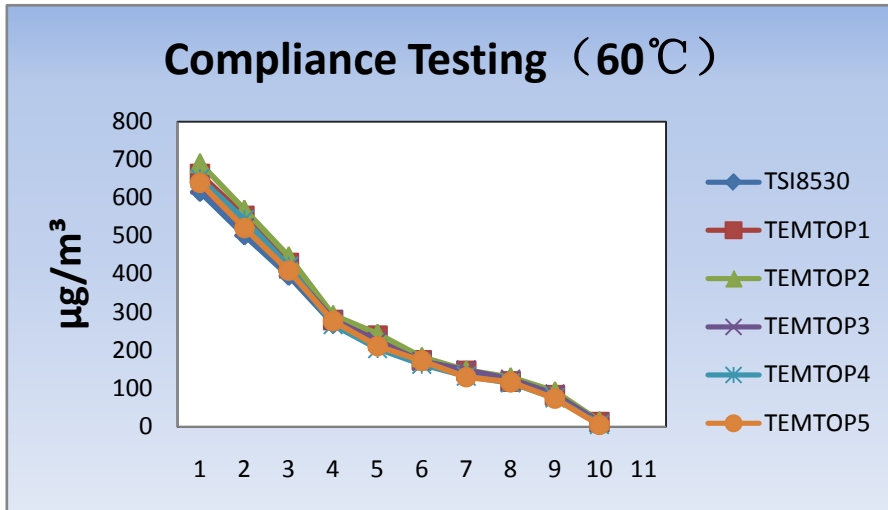

9.4 Compliance after long term running

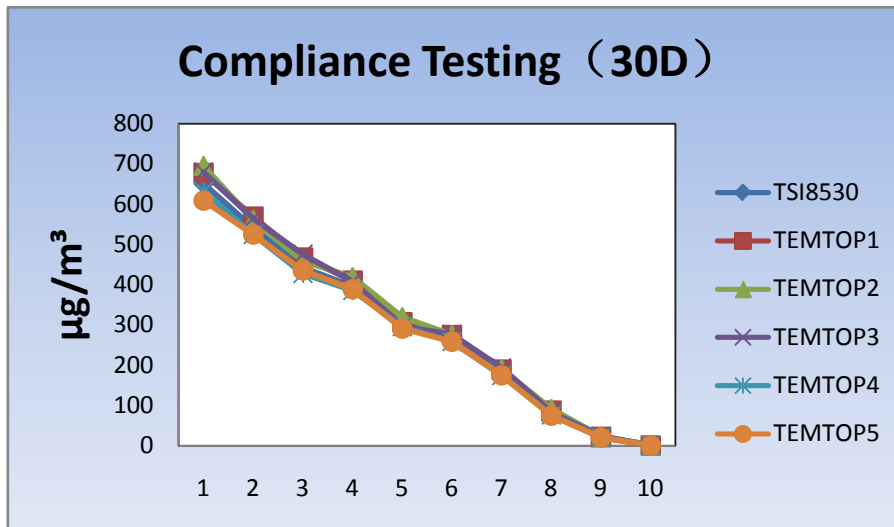

10. Reliability Testing

No.	Test item	Unit	Technical requirements	Quantity	Test result	Result
1	Stores at low temperature	-	Store the sensors for 500 hours at -30°C ±2 °C , then place them at room temperature for 2 hours, and check the compliance.	5PCS	Compliance: 0-100µg/m³: ±10; 100-500µg/m³; ±10%;	Pass
2	Stores at high temperature	-	Store the sensors for 500 hours at 70°C ±2 °C , then place them at room temperature for 2 hours, and check the compliance.	5PCS	500-700µg/m³; ±15%; The fan has no	Pass

3	Stores at high temperature and humidity	-	Place the sensors powered off at 70°C ±2°C and 90-95%RH for 500 hours, then put them at room temperature for 2 hours and test the compliance.	5PCS	obvious abnormal sound; the appearance is not deformed; the output value is stable.	Pass
4	Power on and off	-	Power on the sensors for 5 minutes and then power off for 5 minutes. Repeat such operations for 1000 times. Sample 10 points from 0 to 700µg/m ³ in the testing device. All data complies with the requirements.	5PCS		Pass
5	Operates at low temperature	-	The sensors run for 48 hours continuously at -10°C ±2°C. Sample 10 points from 0-700µg/m ³ in the testing device. All data complies with the requirements. Keep placing the sensors to 120 hours and sample 10 points from 0 to 700µg/m ³ . All data complies with the requirements.	5PCS	Compliance: 0-100µg/m ³ : ±15%; 100-500µg/m ³ : ±15%; 500-700µg/m ³ : ±20%; The fan has no obvious abnormal sound; the appearance is not deformed; the output value is stable.	Pass
6	Operates at high temperature	-	The sensors run for 48 hours continuously at 60°C ±2°C. Sample 10 points from 0 to 700µg/m ³ in the testing device. All data complies with the requirements. Keep placing the sensors to 120 hours and sample 10 points from 0 to 700µg/m ³ . All data complies with the requirements.	5PCS		Pass
7	Cycle testing at high and low temperature	-	Place the sensors powered off at 60°C for 4 hours, and then put them at -20°C environment in 30 seconds for 4 hours. Repeat such operations for 5 times. Place them at room temperature for 2 hours and check the compliance.	5PCS		Pass
8	Operates at high temperature and humidity	-	The sensors continuously run for 2 days at 60°C and 85%RH. Sample 10 points from 0 to 700µg/m ³ in the testing device. All data complies with the requirements. Keep placing the sensors to 5 days and sample 10 points from 0 to 700µg/m ³ . All data complies with the requirements.	5PCS		Pass
9	Operates at low temperature and humidity	-	The sensors continuously run for 48 hours at -10°C and 20%RH. Sample 10 points from 0 to 700µg/m ³ in the testing device. All data complies with the requirements. Keep placing the sensors to	5PCS		Pass

			120 hours and sample 10 points from 0 to 700µg/m ³ . All data complies with the requirements.			
10	Operates at room temperature and high humidity	-	The sensors continuously run for 48 hours at 25°C±2°C and 85%RH. Sample 10 points from 0 to 700µg/m ³ in the testing device. All data complies with the requirements. Keep placing the sensors to 120 hours and sample 10 points from 0 to 700µg/m ³ . All data complies with the requirements.	5PCS	Pass	
11	Dusty test	-	Put 2g dry cement at 25°C and 40%RH in a test chamber and use a fan to blow it. Add 2g dry cement every 24 hours. Keep the sensors running for 48 hours in the chamber. Then place the sensors in a normal test chamber. Sample 10 points from 0 to 700µg/m ³ . All data complies with the requirements. Repeat the testing once and sample 10 points from 0 to 700µg/m ³ . All data complies with the requirements.	5PCS	Pass	
12	Automobile exhaust test	-	Keep the test chamber at 25°C and 40%RH, add 20ml gasoline into the tin furnace and evaporate it at 200°C for 30 minutes. Use a fan to blow in the chamber. Repeat such operations every 12 hours and continue for 2 days. Sample 10 points from 0 to 700µg/m ³ . All data complies with the requirements. Keep placing to 4 days; sample 10 points from 0 to 700µg/m ³ . All data complies with the requirements.	5PCS	Pass	
13	Cooking fume test	-	Keep the test chamber at 25°C and 40%RH, add 20ml cooking oil into the tin furnace and evaporate it at 200°C for 30 minutes. Use a fan to blow in the chamber. Repeat such operations every 12 hours and continue for 2 days. Sample 10 points from 0 to 700µg/m ³ . All data complies with the requirements. Keep placing to 4 days; sample 10 points from 0 to 700µg/m ³ . All data complies with the requirements.	5PCS	Compliance: 0-100µg/m ³ : ±15%; 100-500µg/m ³ ; ±15%; 500-700µg/m ³ ; ±20%; The fan has no obvious	Pass

14	Mixed gas test	-	Test the sensors in automobile exhaust, cooking fumes and dusty environment for 6 days in total (2 days for each test). After all tests finish, sample 10 points from 0 to 700 $\mu\text{g}/\text{m}^3$ in the chamber. All data complies with the requirements.	5PCS	abnormal sound; the output value is stable.	Pass
15	Operate for a long period	-	Place the sensors powered on at room temperature for 30 days and sample 10 points from 0 to 700 $\mu\text{g}/\text{m}^3$. All data complies with the requirements.	10PCS		Pass
16	Vibration	-	Keep the 10 m ³ test chamber at 20 $^{\circ}\text{C}$ and 50% humidity.Vibrate the sensors under the conditions: vibrational frequency 50Hz, accelerated velocity 9.8/S ² , direction of vibration x, y, z, amplitude of vibration (vertical direction) $\pm 2\text{mm}$, test duration60 minutes in x, y, z direction respectively. The particulate generator puffs smoke and the air purifier regulates. Apply DC 5V on the sensors to test their compliance.	5PCS		Pass
17	Zero drift	-	The sensors run for 2 hours and full-span drift is no more than $\pm 15\%$ of standard reading.	5PCS		Pass
18	Full-span drift	-	The sensors run for 2 hours and full-span drift is no more than $\pm 15\%$ of standard reading.	5PCS		Pass
19	Operating current	mA	≤ 100	5PCS		Pass
20	Electrical fast transient burst	I/O Port	The sample sensors work normally after being tested at 4kV peak voltage (level 4) and 5/100kHz group pulse frequency.	5PCS		Pass
21	Electrostatic discharge (ESD)	-	No abnormal phenomena happen after contact discharge with sensor port surface at 1KV test voltage and other surfaces at 8KV (level 4) test voltage.	5PCS		Pass
22	Surge (Shock)	-	Industrial level 4.	5PCS		Pass
23	Drop	-	The sample sensors drop freely at 1m height twice from different angles. Then power on the sensors and they function normally.	5PCS		Pass
24	Salt spray test	-	Place the sensors in a salt spray test chamber at 35 $^{\circ}\text{C}$, apply 5% sodium	5PCS	No rust or color change on the	Pass

			chloride solution to pray them for 48 hours. Then clean them up with water.No red rust is generated on their surface.		metal pieces.	
--	--	--	---	--	---------------	--

11. Installation and Operation Precautions

- The product is used on household appliances. Please do not use it in the fields that require high safety and dependency, such as medical treatment, mining industry, disaster prevention, etc.
- The product adopts non-electrostatic adsorption materials. Please avoid using it in harsh and dusty environment. It is suggested to close the air inlet after use.
- When installing the product, make sure the air inlet and outlet unblocked without large air stream in. See the two figures below for correct installation so that the accuracy is ensured without dust covering on the surface of sensitive elements for a long time.

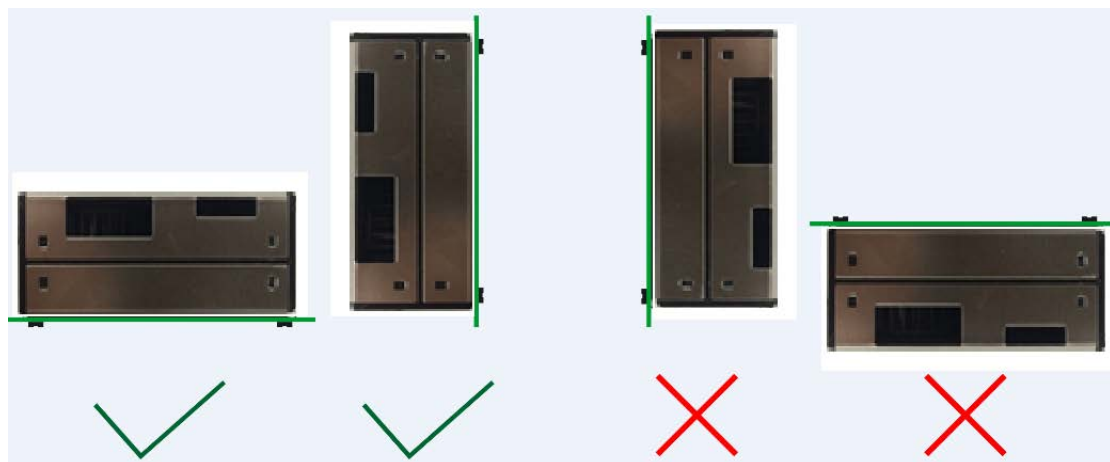

Right

Wrong

- It is best to keep the air inlet and outlet close to the blowhole of the internal surface of user's appliance and communicating with the outside. If not, keep the space around the air outlet unobstructed in 2cm. A structure should be formed to separate the air inlet from the air outlet so that the airflow from the air outlet cannot flow back to the air inlet.
- The blowhole of user's appliance prepared for the air inlet should not be

smaller than the air inlet itself. When applied to a purifier, the product should not be placed directly in the air channel of the purifier. If it has to do so, set an independent structure to put the product in to separate from the air channel of the purifier.

- When applied to a fixed detection device, the sensor should be placed 20cm above the ground. Otherwise, it may cause the fan to be blocked by surficial dust particles or even floccules.

- When applied to an outdoor fixed device, the product should be protected from sand storm, snow and rain or flocs. Do not damage, disassemble the product, including its metal shielding case.

- Install the product in the place that cannot be directly touched by human body, because the metal part of the case connects with the DC ground of its internal circuit board; if touched, it will cause safety problems of the whole product's DC ground. It can only be touched after power off.

- To keep the data of the sensors consistent after leaving factory, we don't take the third party detecting instrument or data correction standard. If user insists, please try to fit the data according to actual collected samples.

- The sensor is for indoor use. If users' device is used in the following environment, additional protection structure should be applied to the sensor. Otherwise, its data compliance may drop due to accumulation of dirt, oil, water, etc.

- 1) Smoking room where the time with yearly dust load above $400\mu\text{g}/\text{m}^3$ is longer than 60% of a year, or the time with yearly dust load above $650\text{g}/\text{m}^3$ is longer than 35% of a year.

- 2) Lampblack environment, e.g. kitchen.

- 3) High mist environment, e.g. SPA, shower room.

12. Contact us

Company: Jiangsu Jingchuang Electronics Co., Ltd

Address: No.1 Huangshan Rd., Tongshan Economic Development Zone, Xuzhou,

Jiangsu

Tel: 0516-68902829

URL: www.ustemtop.com